

# Product Specification

**Ord.-No.:** **103 191**

**Specification:** Concrete base, 16 kg, 300 x 300 x 80 mm with wedge connection clamp, V2A

**Performance:** Concrete base with J.Pröpster-wedge technology (wedge connection clamp) to protect roof structures on flat roofs for Optimal air-termination rods  $\varnothing$  16/10 mm (without thread) or tubular air-termination rods  $\varnothing$  16x3/10mm (without thread).

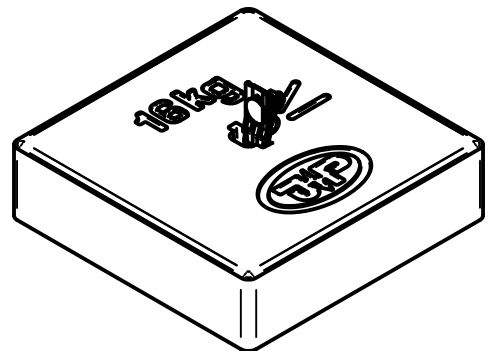
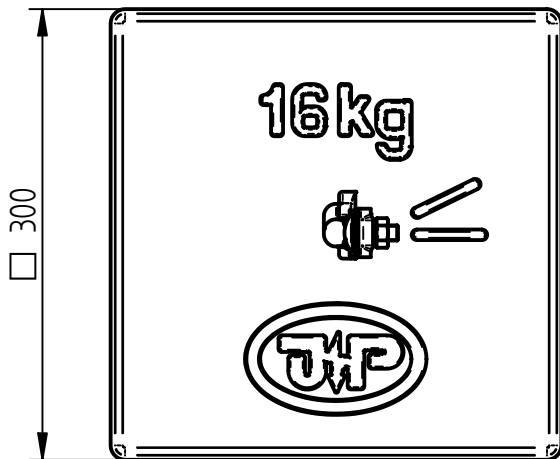
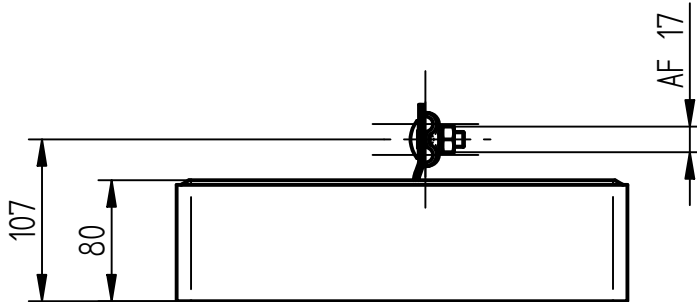

On synthetic roofing membranes a support plate for concrete bases is necessary.

Material	Frostproof concrete (C45/55)
Dimensions	300 x 300 x 80 mm
Weight	16 kg
Wedge connection clamp	Stainless steel V2A
Standard reference	EN 62561-1
Packing unit	1 unit